

MEADOWBROOK SHOPPING CENTER

2001-2153 W 63rd St, Downers Grove, IL
ANCHOR SPACE, INLINE RETAIL & OUTLOTS AVAILABLE FOR LEASE



CONTACT
INFORMATION:

STEVE BAER
sbaer@metrocre.com
847.412.9898

JONATHAN HYMAN
jhyman@metrocre.com
224.365.8144



COMPLETE REDEVELOPMENT

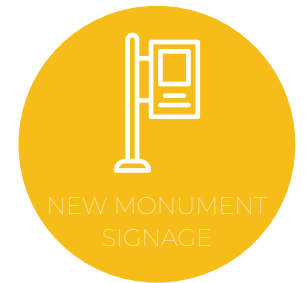

REDEVELOPMENT DETAILS

- New Façade Renovation - To be completed by Q4 '25.
- New Roof - Full roof replacement completed in 2024.
- New Parking Fields - All new asphalt parking fields and striping.
- Landscaping - beautiful new landscaping for a pleasant shopping experience
- New Lighting - Full LED conversion - New lighting fixtures
- New Monument Signage - Located at both 63rd & Woodward entrances

WHAT'S NEW...

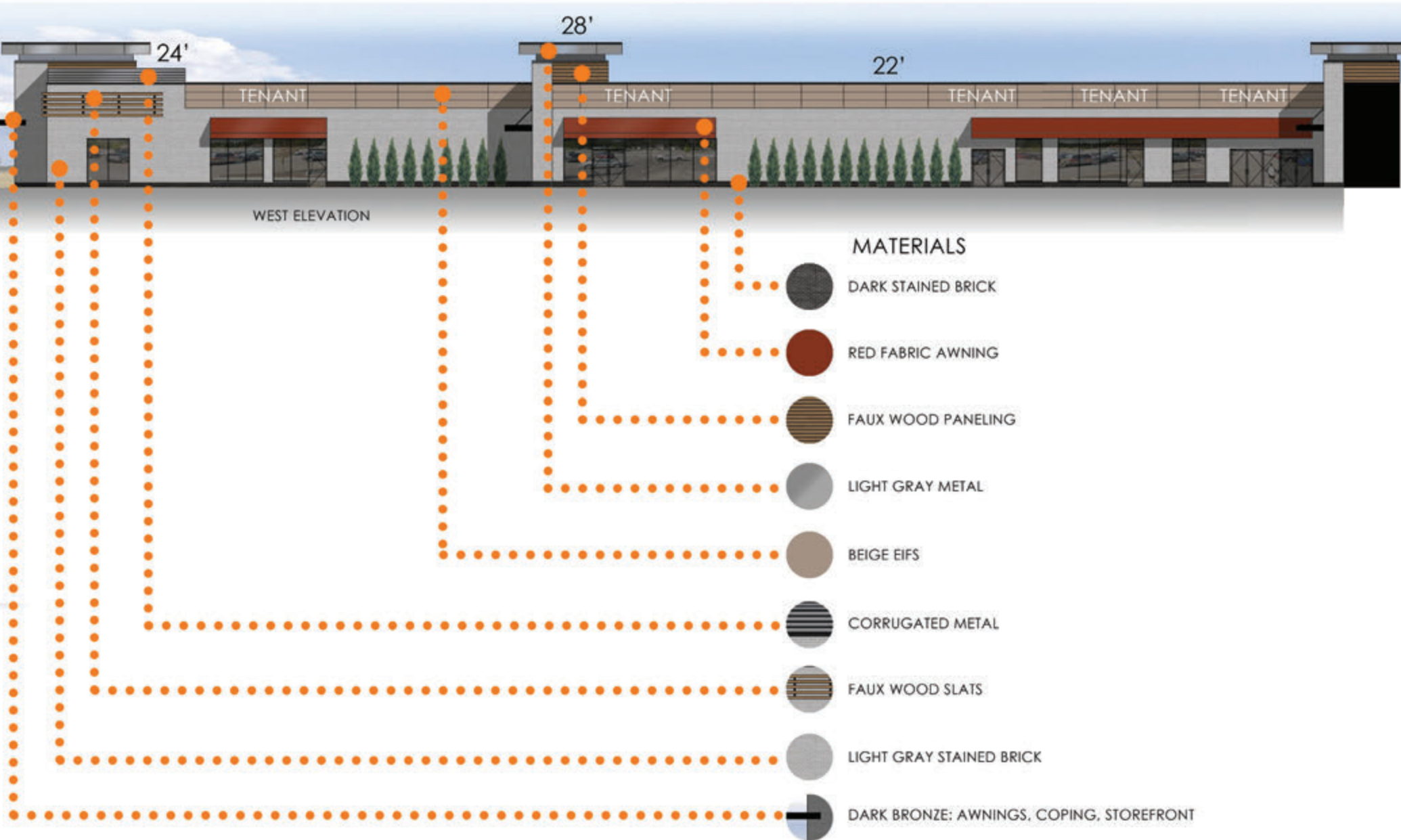

GLIMPSE INTO WHAT'S TO COME

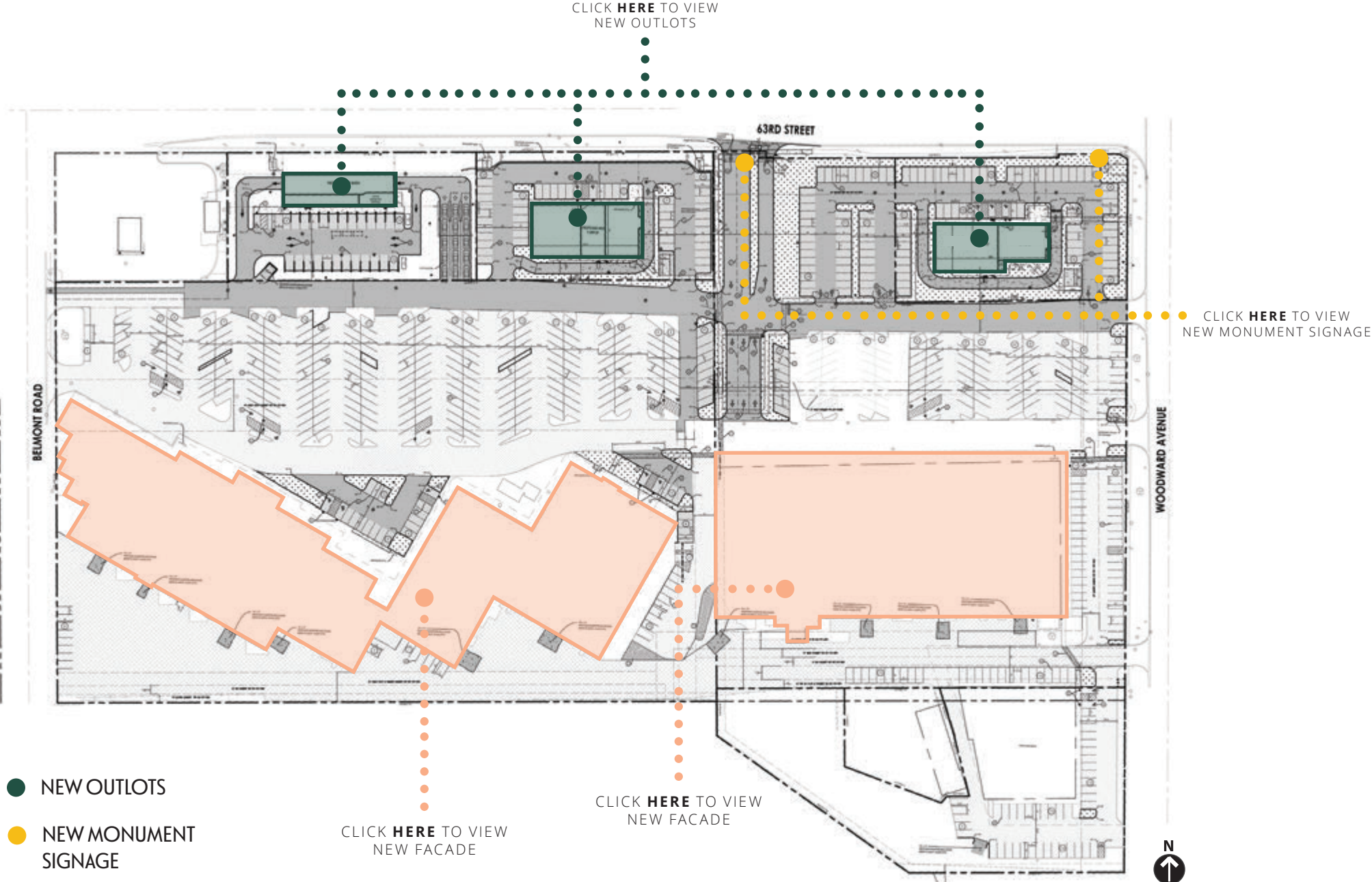

GLA = 188,497 SF
PARKING = 850 STALLS

LOCATION AERIAL

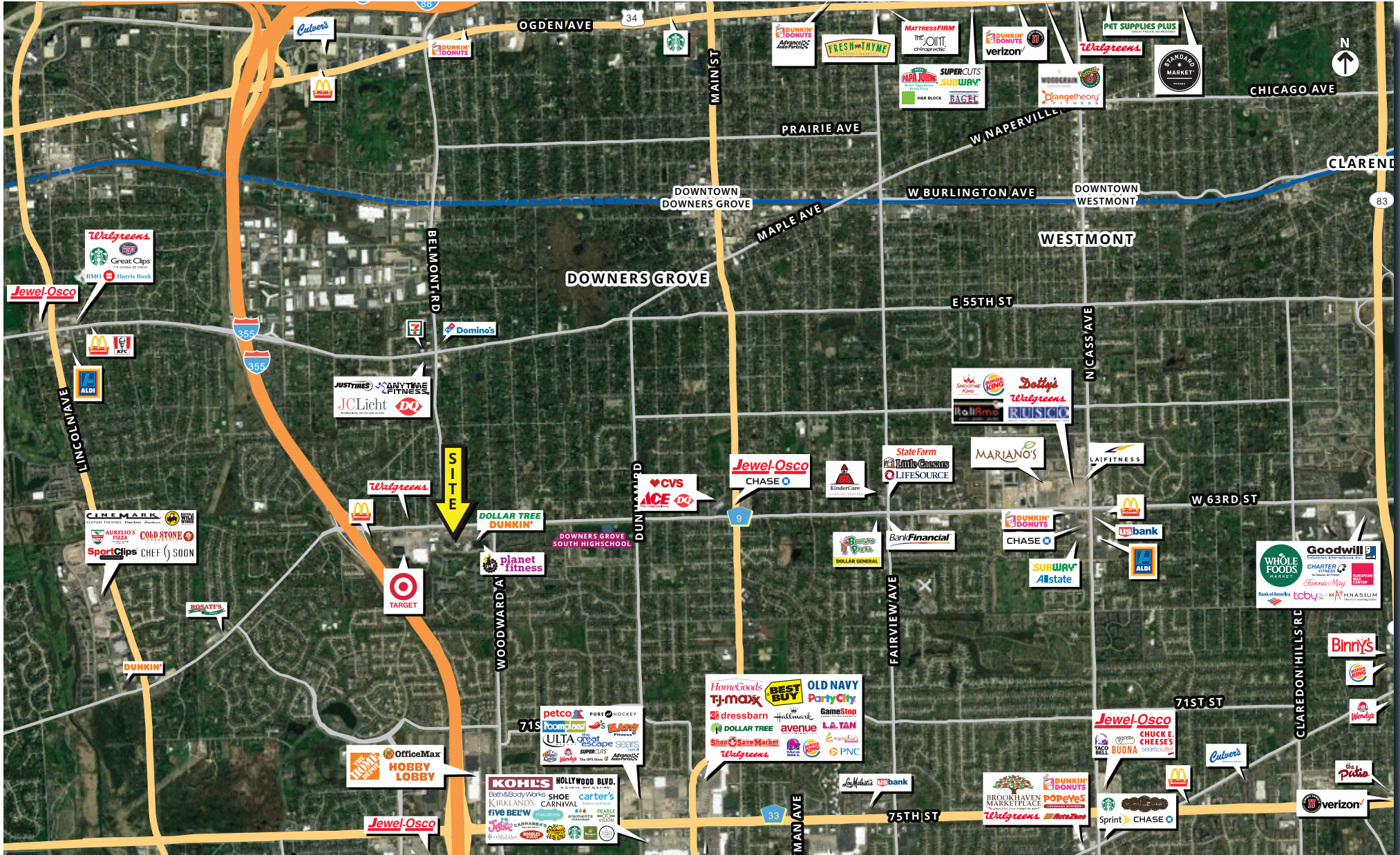

2001-2153 W 63rd St, Downers Grove, IL
FOR LEASE

GET TO KNOW THE AREA

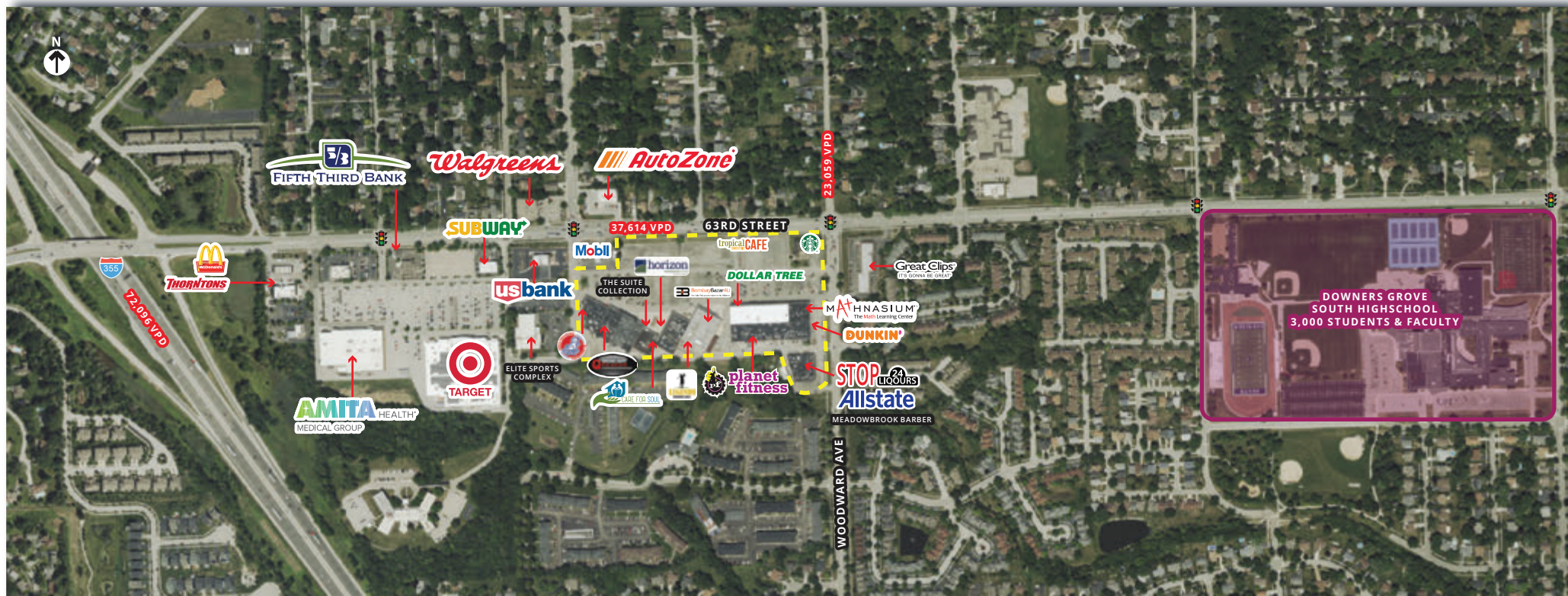

TOTAL POPULATION

1 MI	14,020
3 MI	105,917
5 MI	252,436



HOUSE HOLDS

1 MI	5,592
3 MI	43,833
5 MI	100,010



DAYTIME POPULATION

1 MI	8,058
3 MI	77,750
5 MI	223,246



AVG HH INCOME

1 MI	\$117,005
3 MI	\$123,936
5 MI	\$134,123

TRAFFIC COUNTS

63RD ST	37,614 VPD
I-355	72,096 VPD
WOODWARD AVE	23,059 VPD

AREA TENANTS INCLUDE



MEADOWBROOK SHOPPING CENTER



PYLON C

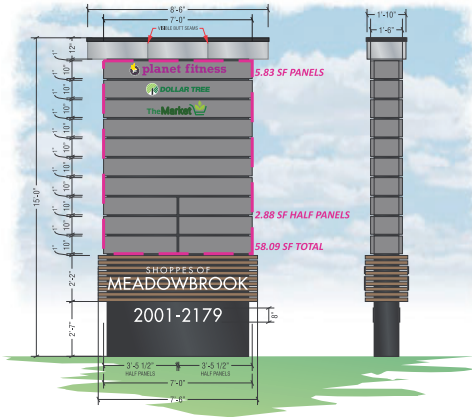

PYLON E

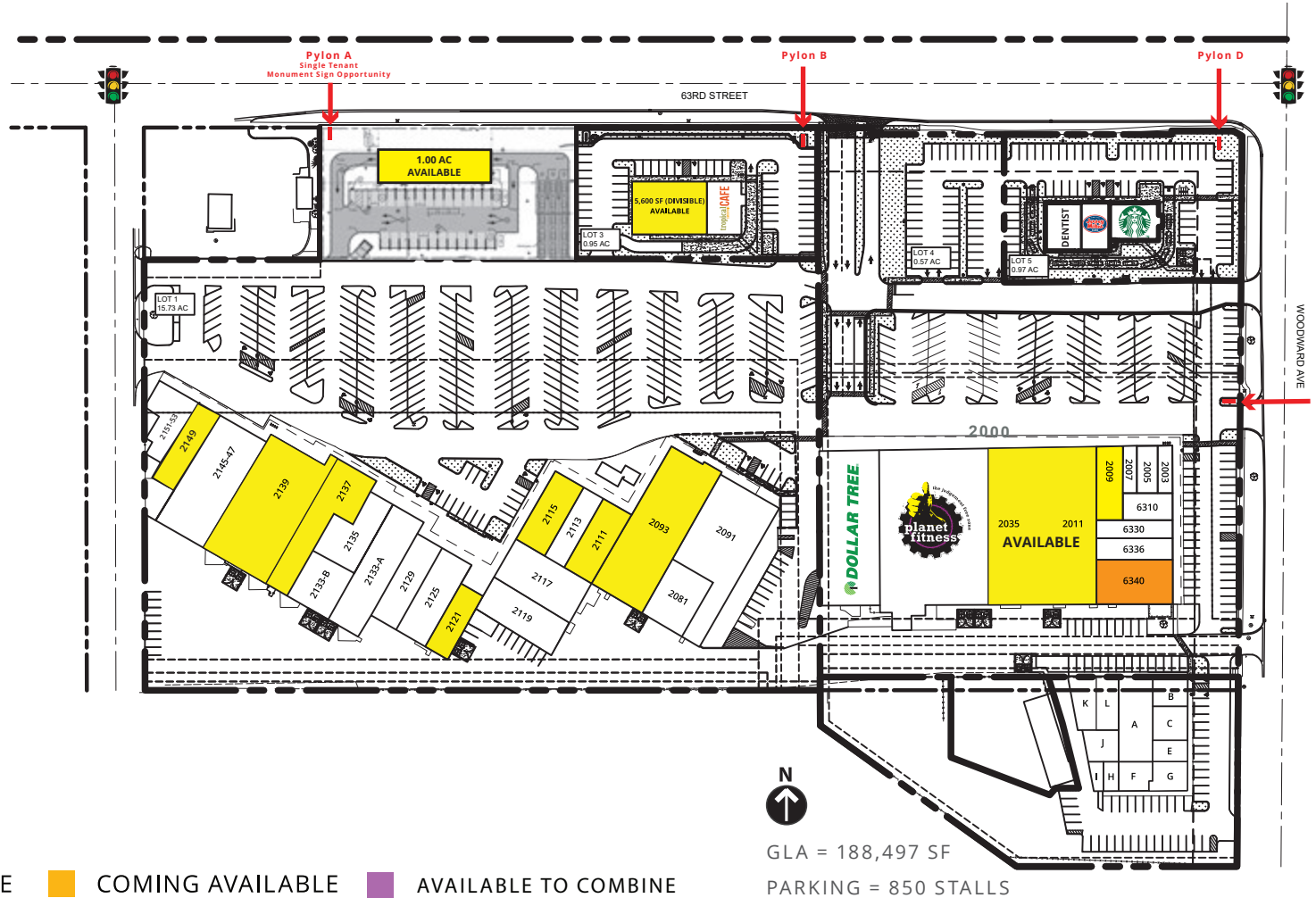
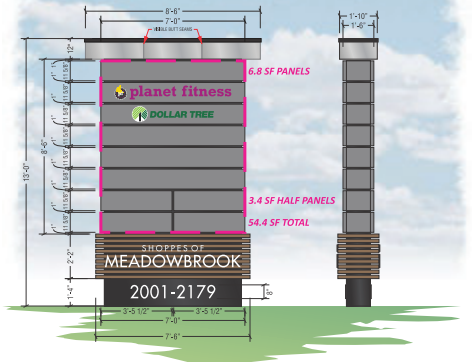

AVAILABLE
 COMING AVAILABLE
 AVAILABLE TO COMBINE

GLA = 188,497 SF

PARKING = 850 STALLS

6400 BUILDING

#	TENANT	SF
6400-A	Love N Care	2,959
6400-B	Stop 24 Foods	1,800
6400-C	Stop 24 Tobacco	1,800
6400-E	American Laser Engraving	650
6400-F	Koller Insurance Services, Inc	1,300
6400-G	Tomahawk Ink	800
6400-H	Meadowbrook Barber	585
6400-I	Cristina's Nutrition Center	875
6400-J	Love N Care	1,460
6400-K	Molly Maid	1,400
6400-L	Love N Care	1,200

6300 - 2000 BUILDING

#	TENANT	SF
6310	Dunkin Donuts	2,160
6330	Heavens Beauty Hair and Spa	2,275
6336	Big D Mart	1,820
6340	2 ND Generation Laundromat	6,340
2003	Maxwell's Beef	900
2005	JK Nails	1,500
2007	Mathnasium	1,200
2009	AVAILABLE	2,833
2011-35	AVAILABLE	23,363

2000 - 2100 BUILDING

#	TENANT	SF
2065	Planet Fitness	20,924
2075	Dollar Tree Store	12,279
2081	Rockys Construction	5,400
2091	KR Golf Inc	7,270
2093	AVAILABLE	12,670
2111	AVAILABLE	2,555
TOTAL COMBINED SF		27,895
2113	Cury Leaves	3,078
2115	AVAILABLE	3,760
2117	Bombay Bazar	4,000
2119	Ninja Squad Gym	4,600

#	TENANT	SF
2121	AVAILABLE	2,375
2125	The Suite Collection Spa and Salon Studios	3,000
2129	Horizon Community Church	4,000
2133-A	Ultimate Treasures	15,023
2133-B	Ultimate Treasures	3,588
2135	Friendly Stitches	2,700
2137	AVAILABLE	1,200
2139	AVAILABLE	6,600
2145-47	Q Billiards	9,930
2149	AVAILABLE	2,300
2151-53	Downers Grove Dog Training and Grooming	2,725

OUTLOT TENANTS

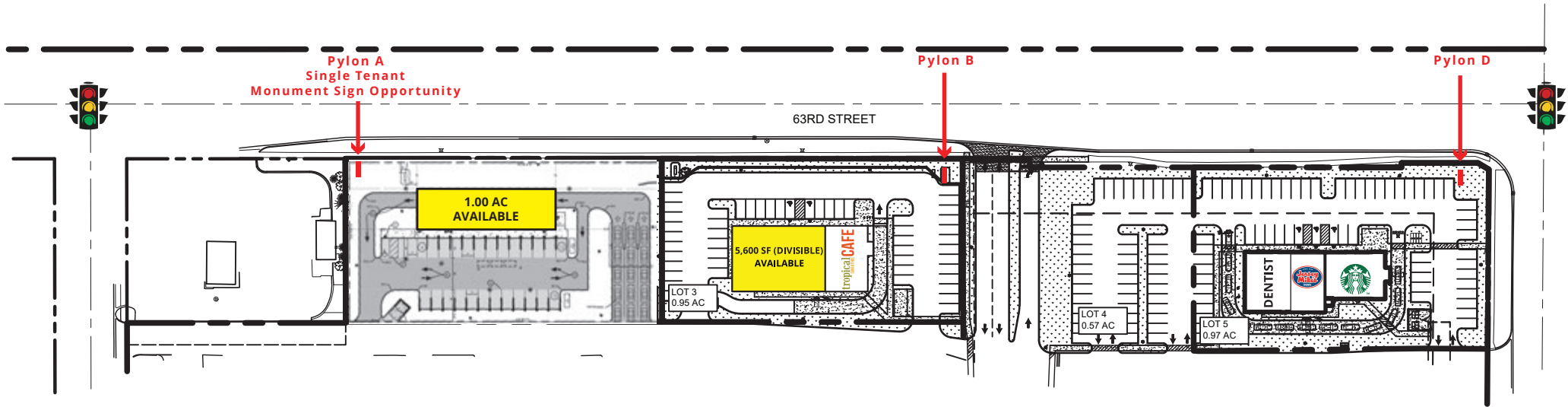

PYLON A

PYLON B

PYLON D

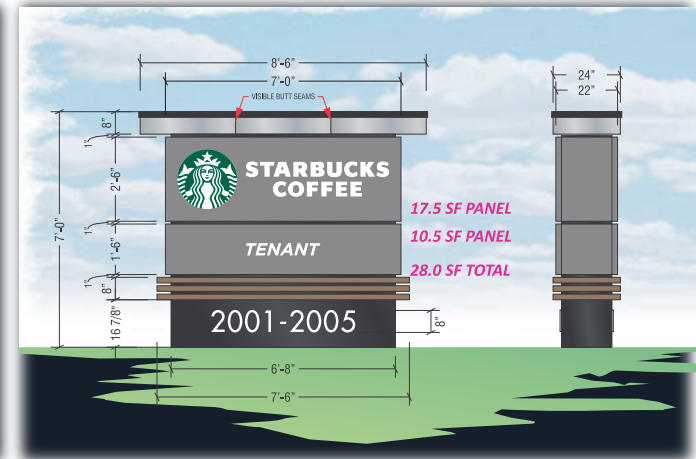
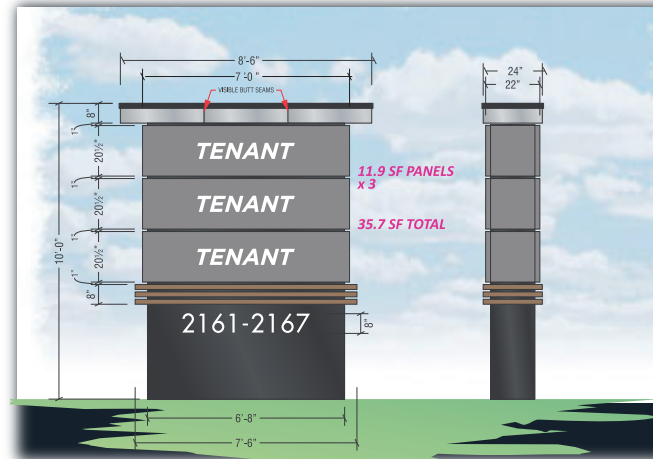
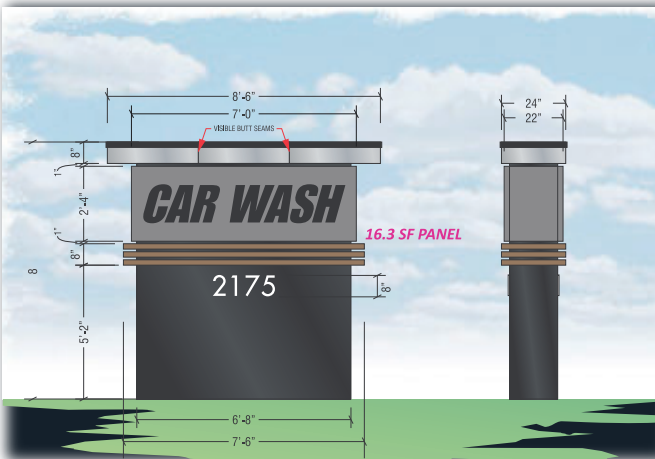

OUTLOT RETAILERS & TRAFFIC GENERATORS:





LEASING CONTACTS



STEVE BAER

SBAER@METROCRE.COM
847.412.9898

JONATHAN HYMAN

JHYMAN@METROCRE.COM
224.365.8144



WWW.METROCRE.COM

© 2025 METRO COMMERCIAL REAL ESTATE. ALL RIGHTS RESERVED. ALL INFORMATION CONTAINED HEREIN IS FROM SOURCES DEEMED RELIABLE; HOWEVER, NO REPRESENTATION OR WARRANTY IS MADE TO THE ACCURACY THEREOF.